

The complete production solution
Your future – All from one source



SMI Linear Pro

Automated Cutting and Fabrication Systems



SMI Linear Pro

Maximum Output and Flexibility

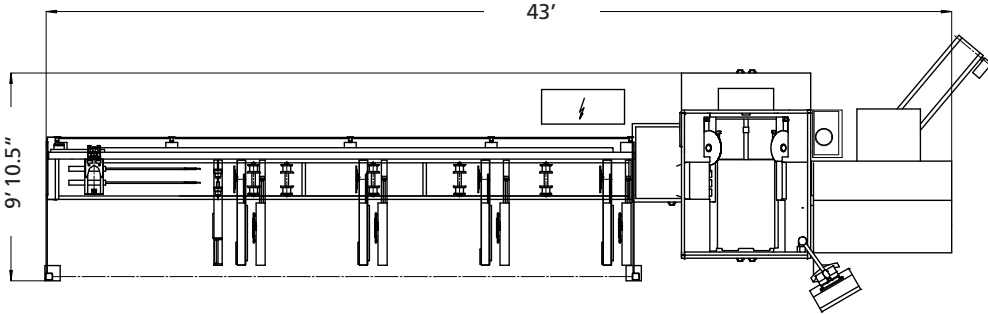

SMI-LinearPro-VHC Cut with double stage pre-loader



The Latest Technology in PVC Window Fabrication

- » Designed in the USA specifically for North American Window and Door production requirements
- » High output at competitive pricing
- » Small footprint for optimum space efficiency
- » Wide range of automation levels and profile flexibility
- » Plug-and-play concept for fast machine installation
- » Links seamlessly with Stürtz Welding and Cleaning Systems
- » Maximum lineal length 22 feet
- » Minimum cut length 6 inches
- » Meets all UL/CSA/CE normal requirements
- » Power supply 240/480 Volt, 3 Phase, 60 Hertz

The **SMI-LinearPro** family of Automated Sawing and Fabrication Centers are designed to meet today's ever changing PVC window and door production needs.

Designed to process two frame parts or up to four sash parts per cycle, the **Linear Motor driven feed system** provides high speed, extremely accurate positioning of the lineals for the most accurate length tolerance available. The feeder system will accept lineals up to 22 feet long to allow for the most efficient optimization yields possible.

This **Through Feed Double Miter Saw** features independent blade stroke for leading and trailing edge cutting to provide minimum scrap loss.

The machine's optional **Integrated Fabrication Systems** are designed to perform multiple window and door fabrication requirements and can be configured several different ways to meet the customers' specific needs, whether its flexibility to run multiple products or high speed production of up to 500 units per shift of a single product.

The exclusive **Stürtz Flying Bridge Technology** allows for on-center fabrication while simultaneously cutting and fabricating the lead end of the product to provide maximum throughput.

SMI Linear Pro

Comfortable Loading, High Speed Cutting,
Flexible Fabrication



Linear Pro VHC-Cut with notching option

SMI Linear Pro VHC-Cut

- » High speed notching capability for sloped sill window systems
- » Horizontal and vertical blade stroke for maximum flexibility
- » Optional servo controlled blade path for notch cutting accuracy and repeatability
- » Optional overhead notching system for compound cut of jamb profile
- » Optional overhead 90° cutting system



Linear Pro V-Cut with 4 sashes

SMI Linear Pro V-Cut

- » The optimum system to cut and fabricate sash products.
- » Horizontal blade stroke for fast, accurate cutting of 45° angles
- » Factory set cutting height to optimize cut cycle on different size profiles
- » Open table top and work area allows easy access for tooling changeover when required



Linear Pro Main Saw

Fast and Powerful Cutting and Fabrication:

- » Standard 550 mm blades
- » Optional 600 mm saw blades for processing larger profiles
- » Wide range of available fabrication tools, including: routing, drilling, dimpling, punching and custom tools

Exclusive “Linear Motion Control” Feeding and Positioning System:

- » State of the art linear motion drive system
- » High speed feed system, up to 13 ft. per second
- » Absolute measuring and closed loop feedback allow for extremely accurate and repeatable positioning at the highest speeds
- » No backlash due to no mechanical parts / gear box



Linear Motion pusher system with optional four gripper configuration

Loading and Feeding Options:

- » Ergonomic manual loading of 2 frame or up to 4 sash bars
- » Standard in-feed roller table with interchangeable rollers
- » Standard “SMART BAR” system automatically measures the size of any remnant pieces to be loaded in the machine whether it is a remake or the end of production run.
- » Optional pre-load system for improved efficiency
- » Optional automatic gripper positioning system to reset the gripping locations for multiple products
- » Optional gripper shifting for double hung sash offset requirements
- » Optional independent dual feeder design to process one complete sash every cut cycle, to provide a true one piece flow system.



Two-stage pre-load system

SMI Linear Pro

Comfortable Loading, High Speed Cutting,
Flexible Fabrication

Fabrication

The **Integrated Fabrication Systems** of the SMI Linear Pro includes software and control systems to allow programmable fabrication to be performed on the profiles from above, below or from the sides. Fabrication can include using punch dies, routers, drills, multi-spindle drills, or dimpling devices as required by the window system for maximum flexibility and throughput.

IFS-I

IFS I System is designed for hard mount tooling programmable through shifting devices and feeder locations.

IFS-II

IFS II System with **Single Axis Tooling Bridge Technology** is designed with over head Y-axis for fully programmable fabrication in both planes of feed, allowing maximum fabrication flexibility.

IFS-III

The IFS III System with exclusive **Flying Bridge Technology** is designed to run in conjunction with the feeding and cutting system to synchronize fabrication requirements, drastically reducing cycle time and increasing throughput.



IFS-I hard mount tooling



IFS-II Tooling Bridge



Hydraulic punching



IFS-III Flying Bridge

Cutting Diagrams

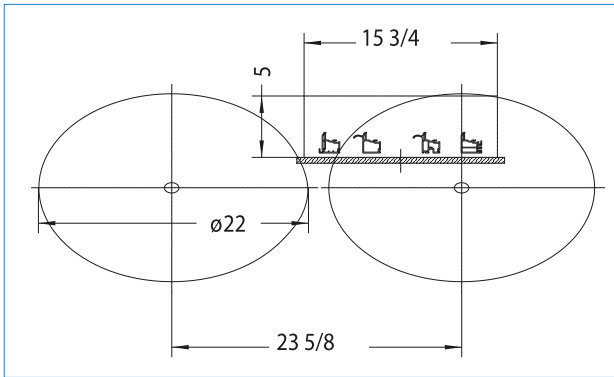

4 double hung sash profiles

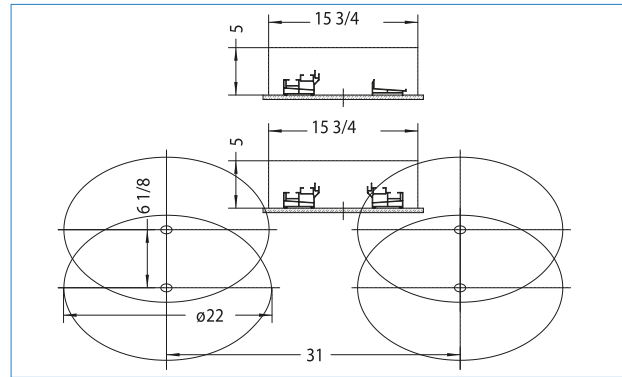

2 double hung frame profiles

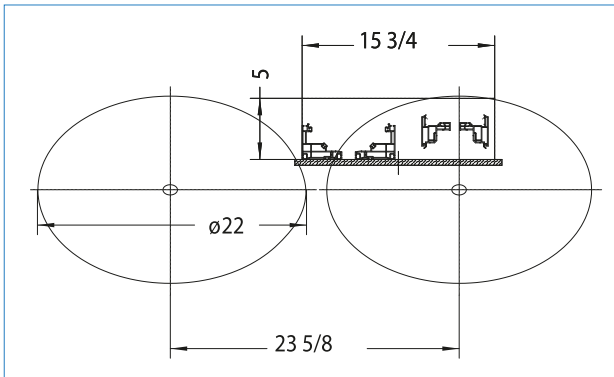

Casement sash/frame profiles

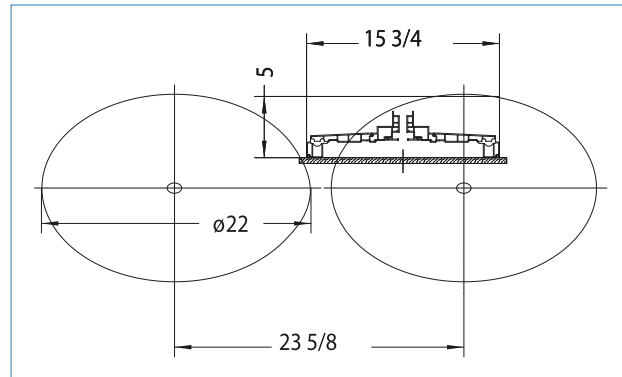

2 large casement frame profiles

Alternative Configurations

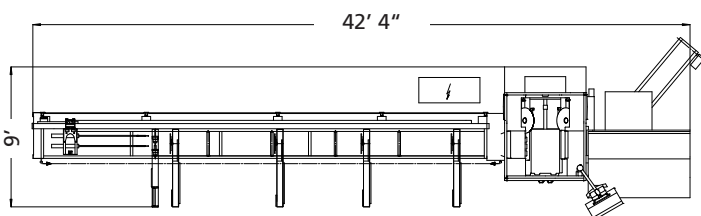

SMI-LinearPro-V with single stage pre-loader

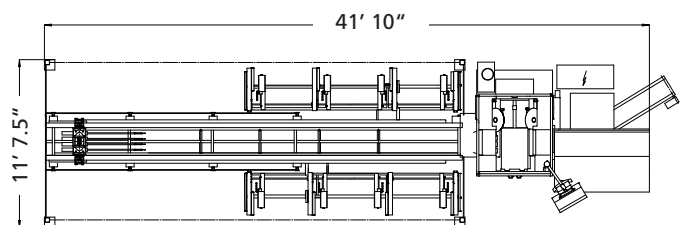

SMI-LinearPro-V with two (2) double stage pre-loaders

SMI Linear Pro

Technical Data/Details



Standard load position display

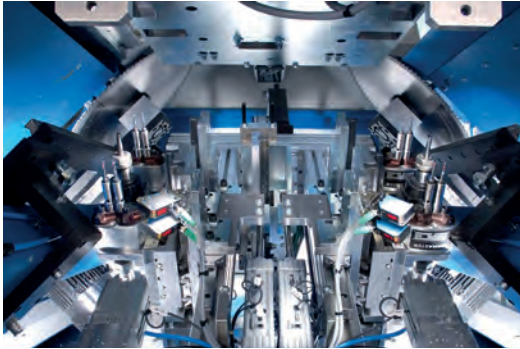

Unique Stürtz lower tool bridge



Tool breakage sensors (optional)

User Interface/Software:

- » Standard PC with 17" flat panel monitor ergonomically attached to the machine
- » NEW simple, graphic programming functions with powerful database
- » Machine is operated by standard Stürtz user interface as used on our welders and cleaners
- » Optional optimization software
- » Optional rest piece management software

Maintenance Features:

- » Automatic function to tilt the lower tool bridge for ease and efficiency of bottom tooling change and maintenance
- » Front and rear access to fabrication tools and for easy maintenance
- » Enhanced machine diagnostics with direct link to machine pictures
- » Software based maintenance scheduling with active on-screen messages
- » Machine log file for production information and other messages

Other Options:

- » Horizontal and vertical incline scrap conveyor
- » Laser sensors to automatically detect a broken tool bit with optional interface to main machine control
- » Barcode scanner
- » Dust collection system
- » Label printer

Stürtz Machinery, Inc.
1910 Summit Commerce Park
Twinsburg, Ohio 44087 – USA

Phone 330 405 0444
Fax 330 405 0445
info@sturtz.com

www.sturtz.com